

| | | |
|----------------------|------------------------|--------------|
| Title | | |
| POWER SUPPLY, RELAIS | | |
| Size | Document Number | Rev |
| A4 | OK1DX | 1.0 |
| Date: | Friday, March 23, 2012 | Sheet 2 of 2 |

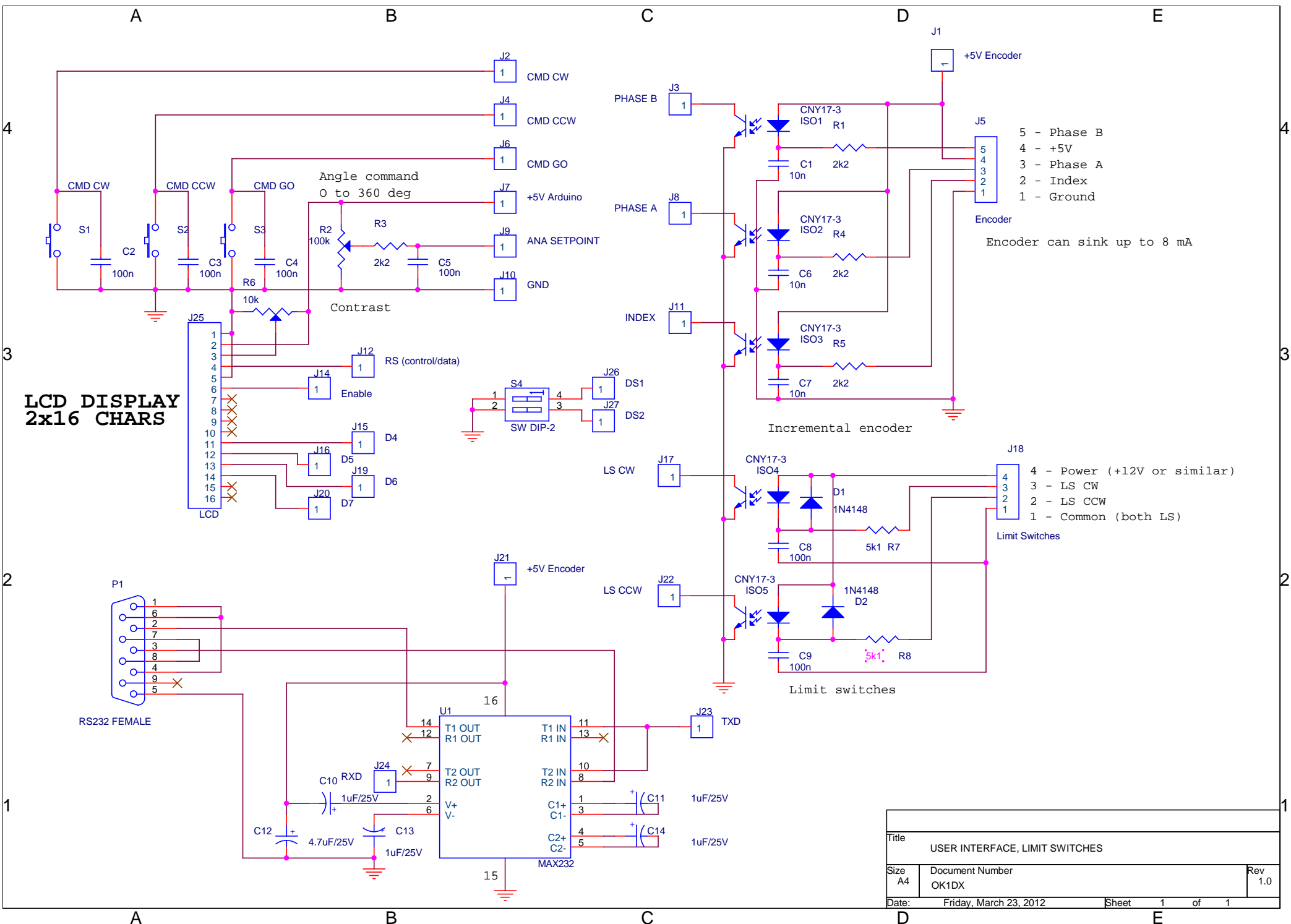

**LCD DISPLAY
2x16 CHARS**

Encoder
Encoder can sink up to 8 mA

5 - Phase B
4 - +5V
3 - Phase A
2 - Index
1 - Ground

Limit Switches

4 - Power (+12V or similar)
3 - LS CW
2 - LS CCW
1 - Common (both LS)

| | | |
|--------------------------------|------------------------|--------------|
| Title | | |
| USER INTERFACE, LIMIT SWITCHES | | |
| Size | Document Number | Rev |
| A4 | OK1DX | 1.0 |
| Date: | Friday, March 23, 2012 | Sheet 1 of 1 |

A B C D E

TRANSFORMER CT

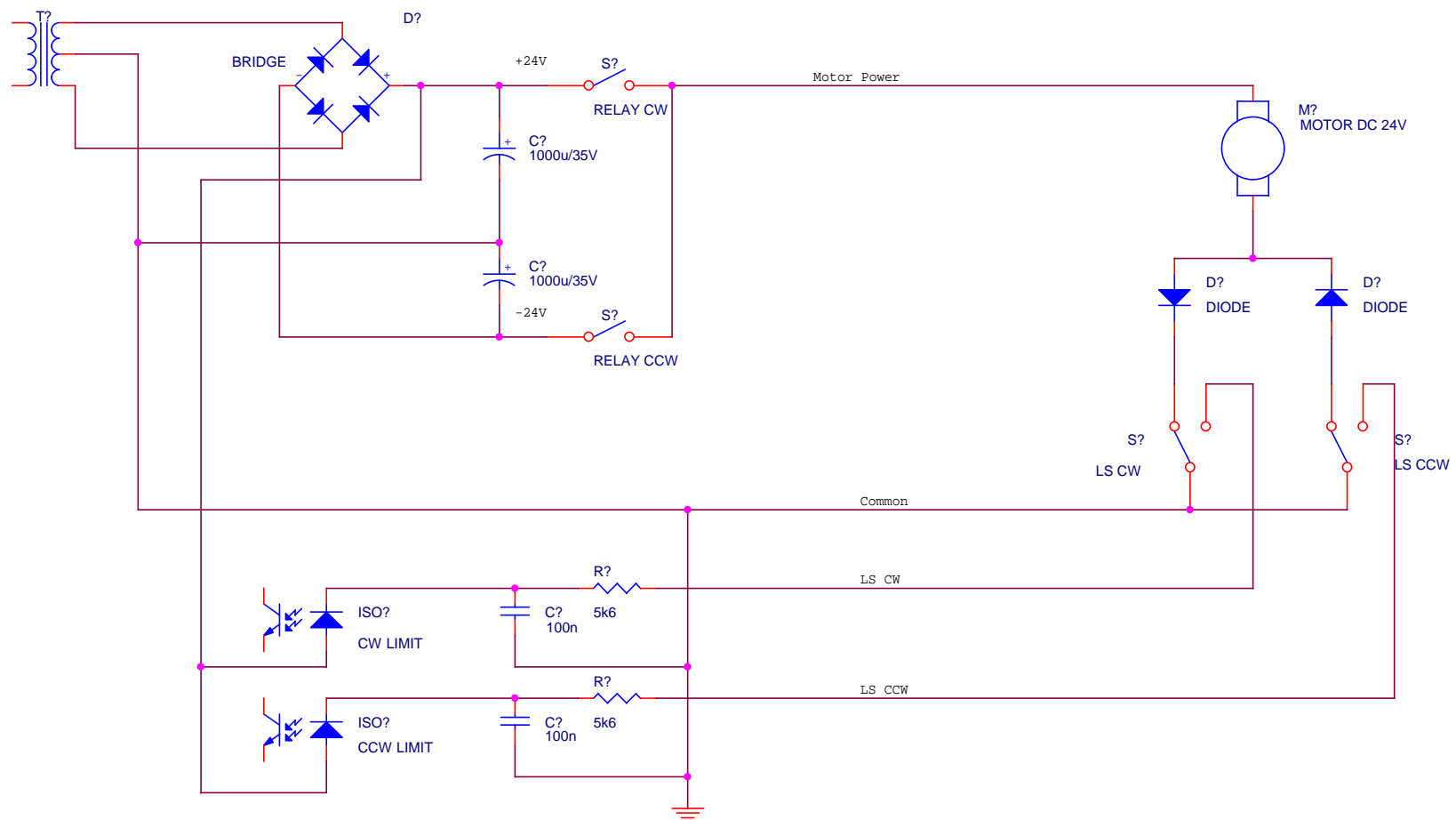

| | | |
|----------|------------------------|--------------|
| Title | | |
| DC MOTOR | | |
| Size | Document Number | Rev |
| A4 | OK1DX | 1.0 |
| Date: | Friday, March 23, 2012 | Sheet 0 of 5 |

A B C D E

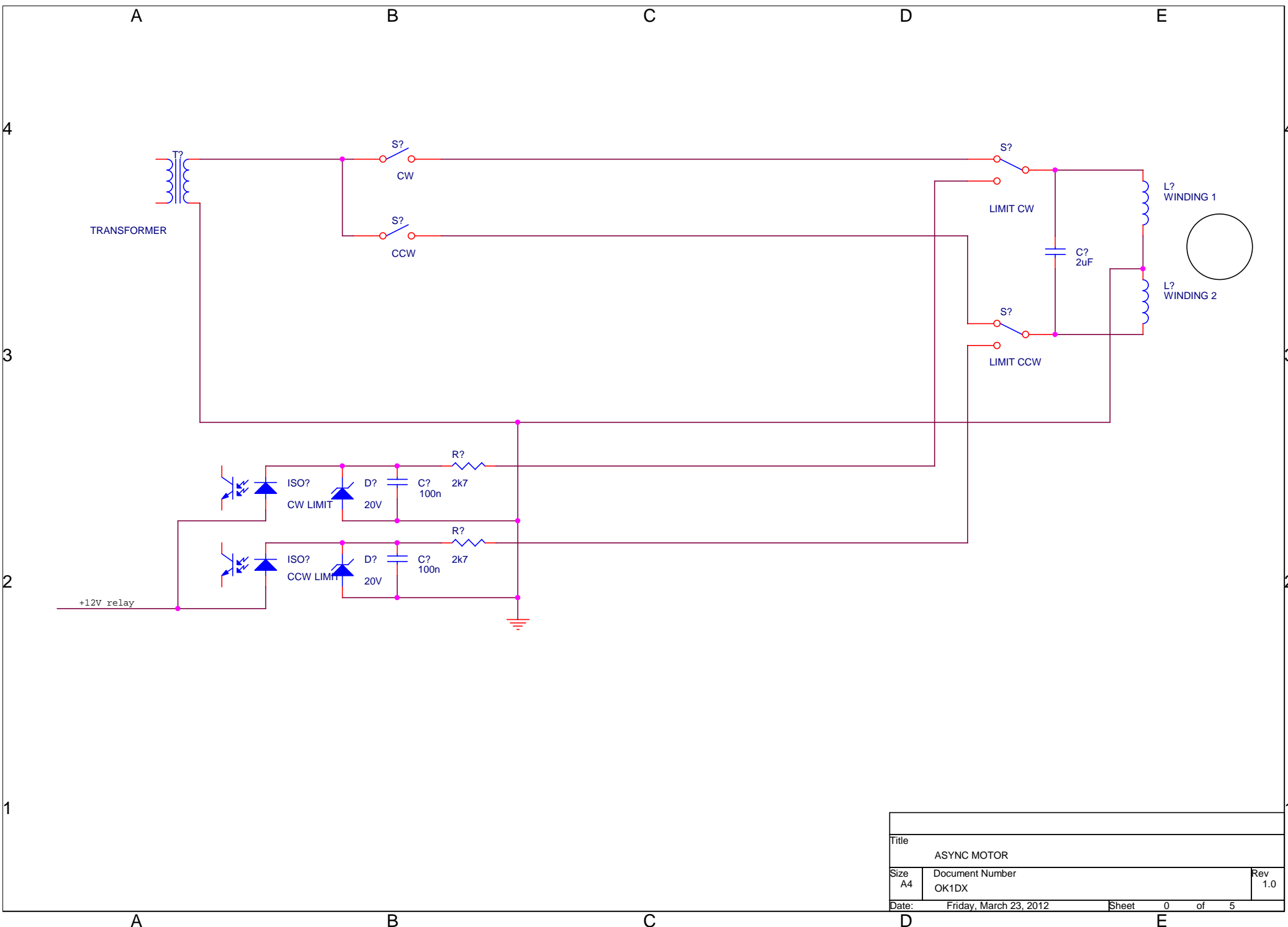

| | | |
|-------------|------------------------|--------------|
| Title | | |
| ASYNC MOTOR | | |
| Size | Document Number | Rev |
| A4 | OK1DX | 1.0 |
| Date: | Friday, March 23, 2012 | Sheet 0 of 5 |